



# 上旋转伸缩挂梁电磁桥式起重机

High level slewing telescopic electromagnetic overhead crane with carrier-beam

本起重机带有可旋转挂梁，适用于钢厂、堆场和仓储等室内或露天的固定跨间，装卸及搬运钢板、型钢、盘卷等物料。特别适用于吊运不同规格且需水平旋转的场合。挂梁下可以携带电磁吸盘、夹钳等专用吊具。

The crane has slewing carrier-beam; is applicable to the fixed span at indoors or outdoors of steel mill, yard and storage, etc. It is used for loading, unloading and carrying steel plate, profile steel, and spool, etc. It is especially applicable to lift materials of different specifications and which needs horizontal rotation. The lower part of the carrier-beam can bring special lifting appliances, such as magnetic chuck and tongs, etc.

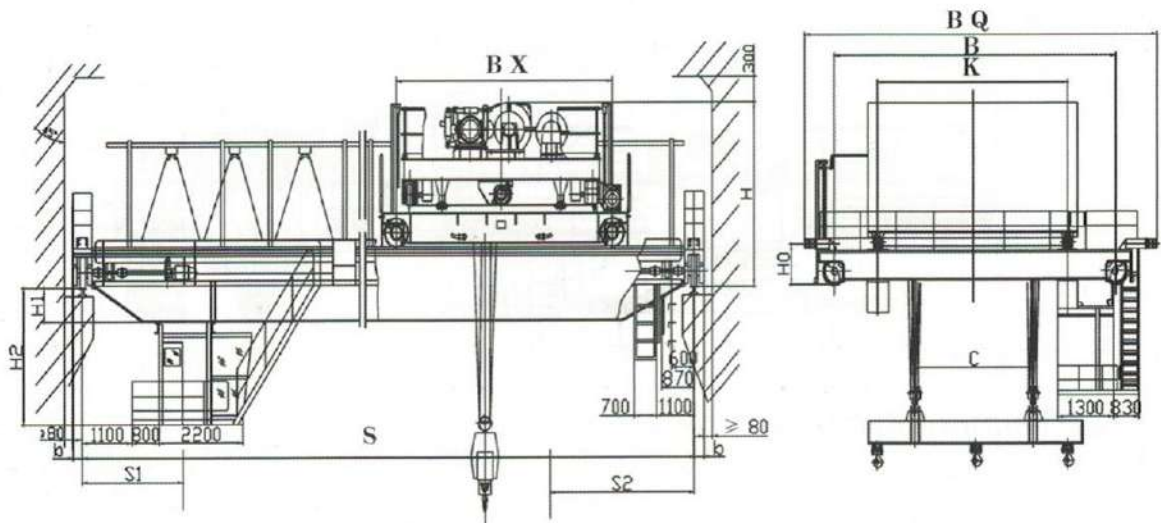

QD(5+5)t 示意图

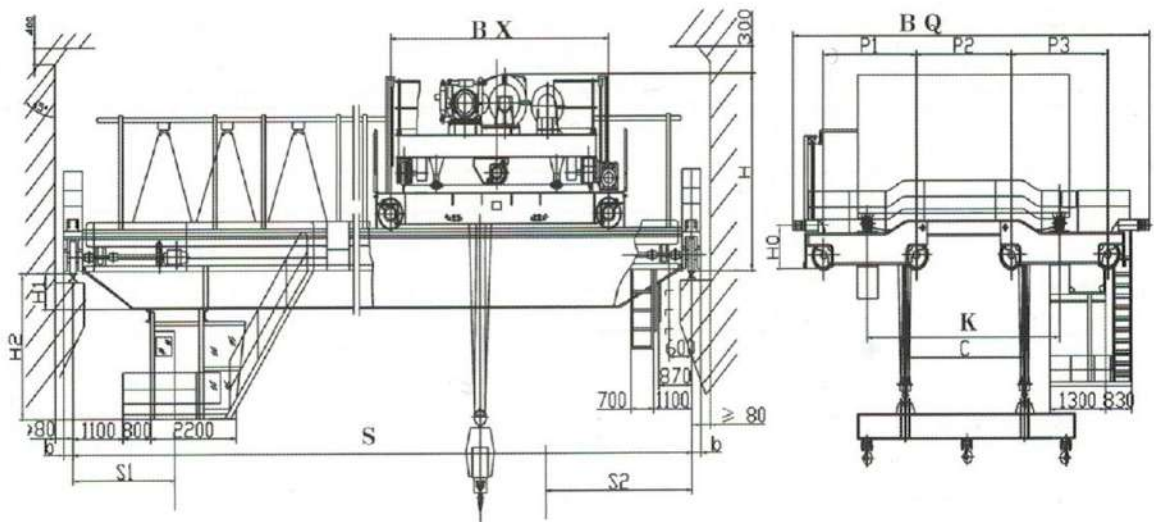

QD(10+10)t-(25+25)t示意图

# 上旋转伸缩挂梁电磁桥式起重机



High level slewing telescopic electromagnetic overhead crane with carrier-beam

## 技术参数 Technological parameter

起重量Lifting Weight		t	5+5	10+10		16+16		25+25	
工作级别 working class			A6	A7		A6		A6	
跨度span		m	28.5	25	34	25	33	25	
最大起升高度Max Lifting Height			12	16	16	10	16	10	
速度 Speed	起升 lifting		m/min	12.4	12.6	12.6	14.8	16	15.4
	运行 travelling	小车运行 Travelling of crab		44.2	42.2	42.2	39	48	40
		大车运行 Travelling of trolley		102	85.2	85.2	106	101	107
	挂梁 Hang beam	回转 Turn round	r/min	1.5	1.36	1.36	1.36	1.85	1.4
主要尺寸(mm) Main Dimensions		H	3100	3900	4100	4200	4195	5000	
		H <sub>1</sub>	692	600	754	750	804	820	
		H <sub>3</sub>	3112	3020	3174	3170	3224	3200	
		H <sub>0</sub>	760	1100	1100	1200	1300	1200	
		BX	5500	7500	7500	7500	7000	7500	
		BQ	8700	10730	10806	10850	10798	1100	
		B	7000						
		K	4000	6000	6000	6000	5500	6000	
		b	260	260	260	260	300	300	
		P <sub>1</sub>		2500	2500	2500	2500	1700	
		P <sub>2</sub>		3500	3500	3500	3000	4300	
		P <sub>3</sub>		3500	2500	2500	2500	1700	
		S <sub>1</sub>	2700	4450	4450	4450	4400	4400	
S <sub>2</sub>	3500	4000	4000	4000	3500	3700			
最大轮压 Max. wheel pressure		KN	65	190	210	255	260	335	
总功率 Total power		KW	50.2	114.8	128.8	151.3	196	243.5	
荐用钢轨 Steel track recommended			43kg / m	QU80				QU100	
电源 Power source			三相交流 3-phase A.C 380V 50Hz						

注:

- 1、进入司机室的走台方式分为：端入、侧入、顶入。
- 2、起重量包含挂梁及专用吊具自重；
- 3、挂梁最大旋转角度可按用户要求；
- 4、以上所有数据为室内使用时；
- 5、参数表中起重机总功率为行车本体功率，不含专用吊具功率。

Note:

1. The modes entering cab: form the end; form the side; form the top.
2. The lifting weight includes deadweight of the carrier-beam and special lifting appliances;
3. The max.rotating angle of the carrier-beam can be made as the user asks;
4. All above-mentioned data is for being used indoors;
5. The total power of the crane in the parameter list is the power of the travelling crane, but excludes the power of special lifting appliances.