

QC型5 ~ 16吨电磁桥式起重机

QC type 5 ~ 16t Electromagnetic Bridge Crane

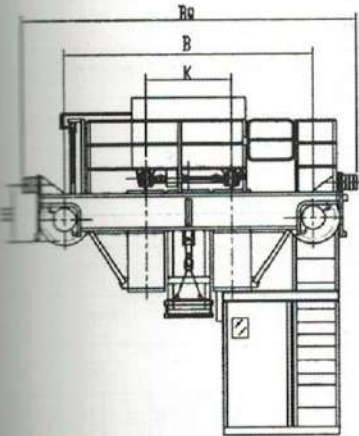

简图: sketch

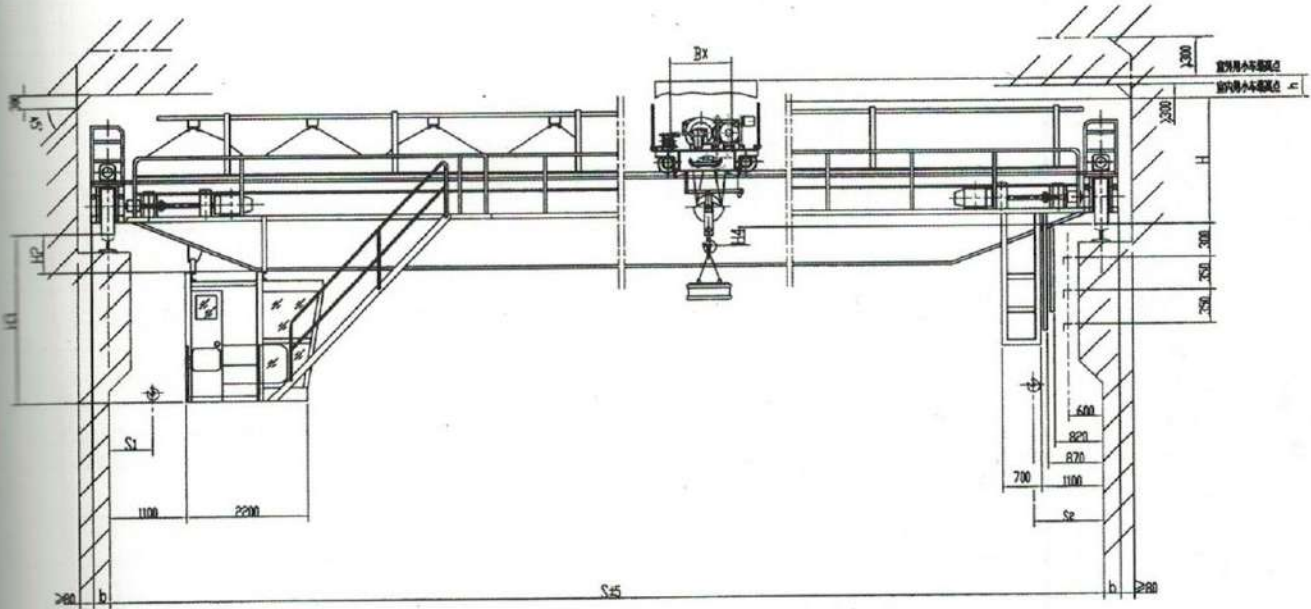

注:

1. 进入操纵室的走台门向位置为: 端面、侧面、顶面。
2. 起重量包括电磁盘自重。
3. 使用电磁盘时, 必须将吊钩旋转部用螺钉锁紧, 不允许转动。

Notes:

- (1) The direction of walkway door to the controlling room is: end, side and top.
- (2) The lifting capacity includes the dead weight of electromagnetic disk.
- (3) When used, the rotary part of the hook of electromagnetic disk must be locked up with screws and no rotation is allowed.

本图所提供重量为设计值, 制造值为 $\pm 5\sim 15\%$ 。

The weight of this sample is design value and actual weight varies $\pm 5\sim 15\%$.



QC型5 ~ 16吨电磁桥式起重机

QC type 5 ~ 16t Electromagnetic Bridge Crane

技术参数 Technological parameter

起重量 Lifting Weight		t	5										10					16											
工作级别 working class			A6																										
跨度 span LQ		m	10.5	13.5	16.5	19.5	22.5	25.5	28.5	31.5	10.5	13.5	16.5	19.5	22.5	25.5	28.5	31.5	10.5	13.5	16.5	19.5	22.5	25.5	28.5	31.5			
最大起升高度 Max Lifting Height		m	16										16					16											
速度 Speed	起升 Hoisting	m/min	15.6										13					13											
	小车运行 Travelling of crab		39.5										43.8					44.5											
	大车运行 Travelling of trolley		92.7					93.7					92.7		93.7		86.4			76		89							
电动机 Motor	起升 Hoisting	KW	YZR180L-6 / 15										YZR225M ₁ -6 / 30					YZR250M ₁ -6 / 37											
	小车运行 Travelling of crab		YZR112M-6 / 1.5										YZR132M ₁ -6 / 2.2					YZR132M ₂ -6 / 3.7											
	大车运行 Travelling of trolley		YZR160M ₁ -6 / 2 × 5.5					YZR160M ₂ -6 / 2 × 7.5					YZR160M ₁ -6 / 2 × 5.5		YZR160M ₂ -6 / 2 × 7.5			YZR160M ₂ -6 / 2 × 7.5		YZR160L-6 / 2 × 11									
主要尺寸 (mm) Main size		B ₀	5390					5450					6100					6040		6130		6330			6235		6835		
		B	3600					3660					5000					4250		4200		5000			4400		5000		
		B _x	1100										1500					1700											
		b	230										230					230		260									
		k	1400					1500					2000																
		H	1764										2028					2026		2076			2095		2097		2187		
		H ₃	2526	2546	2596	2756	2906	3056	3206	3356	2528	2548	2598	2758	2908	3008	3158	3308	2570	2572	2552	2622	2770	2920	3070	3220			
		H ₁	735										790					880											
		S ₁	1250										1500					1900											
		S ₂	1500																										
		H ₂	122	126	226	376	526	676	826	976	122	128	228	378	528	628	778	928	180	182	182	242	390	540	690	840			
		h	850										720					700											
重量 Weight	小车 crab	t	2.496										4.662					5.55											
	总重 Total weight		13.64	15.45	17.44	19.96	22.34	26.64	29.84	32.84	19.5	21.4	24.2	25.9	28.7	33	36.3	39.2	20.6	22.5	25.8	29.1	31.8	35.9	39.4	42.3			
最大轮压 Max. wheel pressure		KN	72	79	87	94	104	114	122	134	115	122	129	138	145	157	164	173	143	153	162	173	184	194	204	213			
电磁盘 electromag-netic disk	型号 Model		MW ₁ -6					MW ₁ -16					MW ₁ -16					MW ₁ -16											
	吸重 attracting weight	kg	4540					3330					8330					14330											
			自重 dead weight		460					1670					1670					1670									
	直径 Diameter		mm	776					1180					1180					1180										
荐用钢轨 Steel track recommended			43Kg / m																										
电源 Power source			三相交流 3-Phase A.C 50Hz 380V																										

QC型16 / 3.2 ~ 32 / 5主钩电磁桥式起重机



QC Type 16 / 3.2 ~ 32 / 5t Main Hook Electromagnetic Bridge Crane

简图: sketch

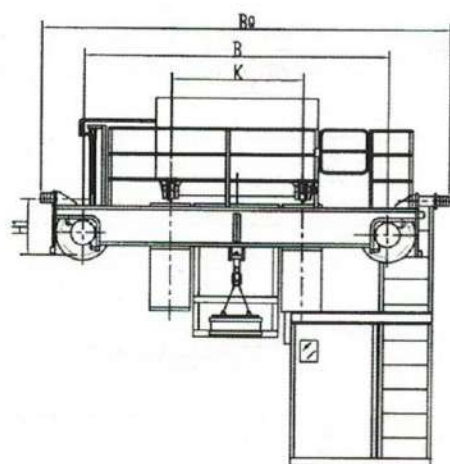
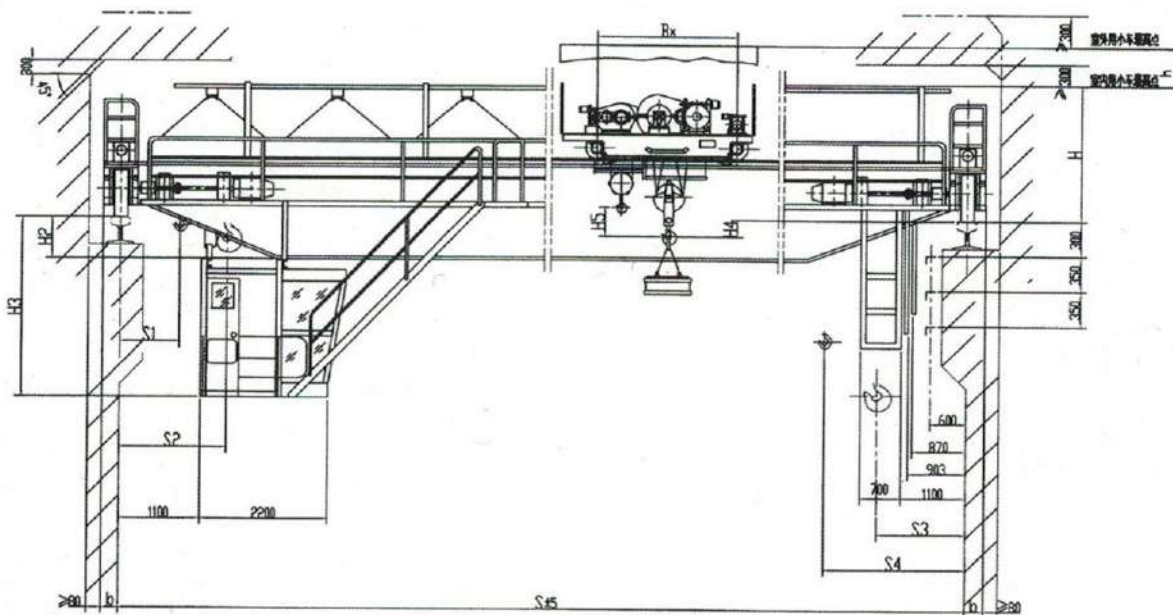

注:

1. 进入操纵室的走台门向位置为: 端面、侧面、顶面。
2. 起重量包括电磁盘自重。
3. 使用电磁盘时, 必须将吊钩旋转部用螺钉锁紧, 不允许转动。

Notes:

- (1) The direction of walkway door to the controlling room is: end, side and top.
- (2) The lifting capacity includes the dead weight of electromagnetic disk.
- (3) When used, the rotary part of the hook of electromagnetic disk must be locked up with screws and no rotation is allowed.

本样本所提供重量为设计值, 制造值为 $\pm 5\sim 15\%$ 。

The weight of this sample is design value and actual weight varies $\pm 5\sim 15\%$.



QC型16 / 3.2 ~ 32 / 5主钩电磁桥式起重机

QC Type 16 / 3.2 ~ 32 / 5t Main Hook Electromagnetic Bridge Crane

技术参数 Technological parameter

起重量Lifting Weight		t	16 / 3.2 (主钩电磁) (Main Hanger Electromagnetic)								20 / 5 (主钩电磁) (Main Hanger Electromagnetic)								32 / 5 (主钩电磁) (Main Hanger Electromagnetic)												
工作级别 working class			A6																												
跨度span		m	10.5	13.5	16.5	19.5	22.5	25.5	28.5	31.5	10.5	13.5	16.5	19.5	22.5	25.5	28.5	31.5	10.5	13.5	16.5	19.5	22.5	25.5	28.5	31.5					
最大起升高度 Max Lifting Height		m	16 / 18								12 / 14								16 / 18												
速度 Speed	起升 Hoisting	电磁 electromagnetic	13								12.6								9.5												
		副钩 Aux.Hook	14.6								15.5								15.5												
	小车运行 Travelling of crab		m/min	44.6								44.6								43.4											
	大车运行 Travelling of trolley			76				89				76				89				89				75.3				75.3			
电动机 Motor	起升 Hoisting	电磁 electromagnetic	YZR250M ₁ -6 / 37								YZR250M ₂ -6 / 45								YZR280M ₁ -8 / 55												
		副钩 Aux.Hook	YZR160L-6 / 13								YZR180L-6 / 17								YZR180L-6 / 17												
	小车运行 Travelling of crab		KW	YZR132M ₂ -6 / 3.7								YZR132M ₂ -6 / 3.7								YZR160M ₁ -6 / 5.5											
	大车运行 Travelling of trolley			YZR160M ₂ -6 / 2 × 7.5				YZR160L-6 / 2 × 11				ZR160M ₂ -6 / 2 × 7.5				YZR160L-6 / 2 × 11				YZR160L-6 / 2 × 11				YZR180L-8 / 2 × 11							
主要尺寸 (mm) Main size			B ₀	6274				7004				6274				7004				6574				6744				7044			
			B	4400				5000				4400				5000				4650				4700				5000			
			B _x	2935								2950								3150											
			b	230				260				230				260				230				260							
			K	2000								2000								2500											
			H	2097	2099	2189				2099	2101	2191				2345	2349	2479													
			H ₃	2572	2552	2622	2772	2922	3072	3222	2572	2576	2556	2626	2774	2924	3074	3224	2582	2588	2618	2648	2798	2948	3098	3198					
			H ₁	850				940				850				940				940				1070							
			S ₁	1040								1070																			
			S ₂	2460								2650																			
			S ₃	1600								1700																			
			S ₄	3020								3280																			
			H ₂	82	182	242	392	542	692	842	82	86	186	246	394	544	694	844	92	98	248	268	418	568	718	818					
			h	820																											
重量 Weight	小车crab		6.822								7.885								12.21												
	总重Total weight		t	20.61	22.11	24.4	28.2	31.5	35.66	39.36	42.82	21.86	23.75	26.27	30.94	33.83	38.3	42.29	46.04	28.92	31.24	34.5	39.85	44.18	48.56	52.24	57.14				
最大轮压 Max. wheel pressure		KN	146	153	161	174	182	193	204	214	170	177	187	201	210	223	234	245	245	258	272	289	304	317	327	341					
电磁盘 electromag -netic disk	型号 Model		MW5-165L								MW5-180L								MW5-210L												
	吸重 attracting weight		kg	12500								14500								21000											
	自重 dead weight			3200								4230								7000											
	直径 Diameter		mm	1650								1800								21000											
荐用钢轨 Steel track recommended			43Kg / m QU70																												
电源 Power source			三相交流 3-Phase A.C 50Hz 380V																												

QC型20 / 5 ~ 32 / 5吨副钩电磁桥式起重机



QC Type 20 / 5 ~ 32 / 5t Auxiliary Hook Electromagnetic Bridge Crane

简图: sketch

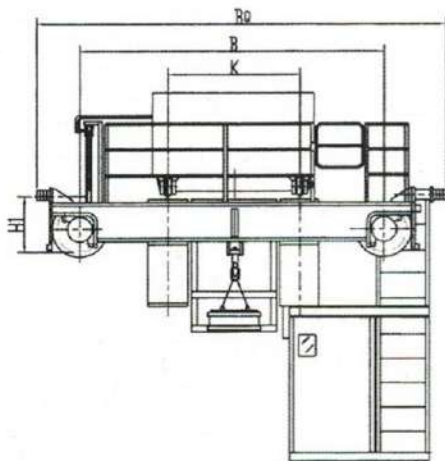
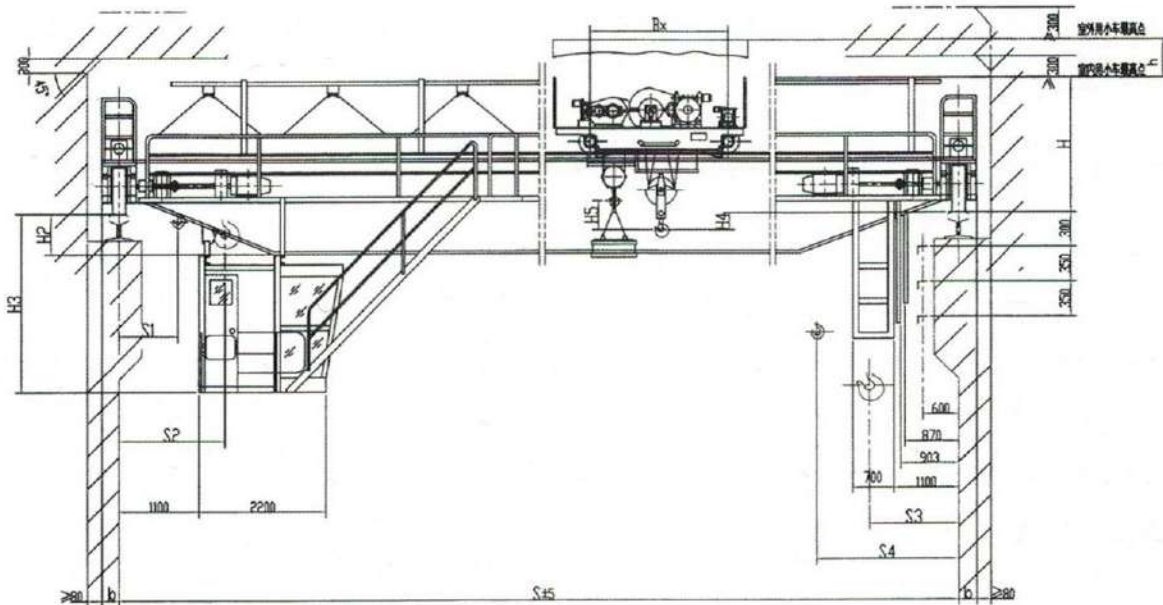

注:

1. 进入操纵室的走台门向位置为: 端面、侧面、顶面。
2. 起重量包括电磁盘自重。
3. 使用电磁盘时, 必须将吊钩旋转部用螺钉锁紧, 不允许转动。

Notes:

- (1)The direction of walkway door to the controlling room is: end, side and top.
- (2)The lifting capacity includes the dead weight of electromagnetic disk.
- (3)When used, the rotary part of the hook of electromagnetic disk must be locked up with screws and no rotation is allowed.

本样本所提供重量为设计值, 制造值为 $\pm 5\sim 15\%$ 。

The weight of this sample is design value and actual weight varies $\pm 5\sim 15\%$.



QC型20 / 5 ~ 32 / 5吨副钩电磁桥式起重机

QC Type 20 / 5 ~ 32 / 5t Auxiliary Hook Electromagnetic Bridge Crane

技术参数 Technological parameter

起重量Lifting Weight		t	20 / 5 (副钩电磁) (Aux Hanger Electromagnetic)						32 / 5 (副钩电磁) (Aux Hanger Electromagnetic)							
工作级别 working class			A6													
跨度span		m	13.5	16.5	19.5	22.5	25.5	28.5	31.5	13.5	16.5	19.5	22.5	25.5	28.5	31.5
最大起升高度Max Lifting Height		m	12 / 14						16 / 18							
速度 Speed	起升 Hoisting	电磁 electromagnetic	15.6						15.6							
		吊钩 Hook	9.8						9.5							
	小车运行 Travelling of crab		m/min	44.6						42.4						
	大车运行 Travelling of trolley			76	89					89	75.3	75.3				
电动机 Motor	起升 Hoisting	电磁 electromagnetic	YZR180L-6 / 15						YZR180L-6 / 15							
		吊钩 Hook	YZR250M ₂ -6 / 45						YZR280M-8 / 55							
	小车运行 Travelling of crab		KW	YZR132M ₂ -6 / 3.7						YZR160M ₁ -6 / 5.5						
	大车运行 Travelling of trolley			ZR160M ₂ -6 / 2×7.5	YZR160L-6 / 2×11					YZR160L-6 / 2×11			YZR180L-8 / 2×11			
主要尺寸 (mm) Main size		B ₀	6244			6734			6574	6744			7044			
		B	4300			5300			4650	4700			5000			
		B _x	2950						3150							
		b	230		260				260		300					
		k	2000						2500							
		H	2097		2187				2347		2477					
		H ₃	2522	2552	2622	2770	2920	3070	3220	2586	2618	2646	2796	2946	3096	3196
		H ₁	850		940				940		1070					
		S ₁	1250													
		S ₂	2650						2650							
		S ₃	1700													
		S ₄	3100						3100							
		H ₂	84	184	244	392	542	692	842	96	246	266	416	566	718	816
		h	820													
重量 Weight	小车crab		7.757						12.17							
	总重Total weight		t	23.75	26.27	30.94	33.83	38.3	42.29	46.04	31.24	34.5	39.85	44.18	48.56	52.24
最大轮压Max. wheel pressure		KN	177	187	201	210	223	234	245	258	272	298	304	317	327	340
电磁盘 electromag -netic disk	型号 Model		MW5-90L													
	吸重 attracting weight		4200						4200							
	自重 dead weight		800						800							
	直径 Diameter		900						900							
荐用钢轨Steel track recommended		QU70														
电 源Power source		三相交流 3-phase A.C 380V 50Hz														